

## eMOTUS50D

WALL-MOUNT LOUDSPEAKERS

*Outdoor loudspeaker*



**USER MANUAL**

# INDEX

1. IMPORTANT REMARK.....	3
2. IMPORTANT SAFETY INSTRUCTIONS .....	3
3. IMPORTANT NOTE.....	5
4. INTRODUCTION.....	5
5. KEY FEATURES.....	5
6. CONNECTING .....	6
7. POSITIONING, FITTING AND START-UP .....	7
8. REAR PANEL.....	9
9. TECHNICAL SPECIFICATIONS .....	9
10. PACKING CONTENT .....	10

## 1. IMPORTANT REMARK



WARNING: SHOCK HAZARD - DO NOT OPEN

AVIS: RISQUE DE CHOC ÉLECTRIQUE - NE PAS OUVRIR



The lightning flash with arrowhead symbol, within an equilateral triangle, is intended to alert the user to the presence of uninsulated “dangerous voltage” within the product’s enclosure that may be of sufficient magnitude to constitute a risk of electric shock to persons.



The exclamation point within an equilateral triangle is intended to alert the user to the presence of important operating and maintenance (servicing) instructions in the literature accompanying the appliance.

**WARNING (If applicable):** The terminals marked with symbol of “” may be of sufficient magnitude to constitute a risk of electric shock. The external wiring connected to the terminals requires installation by an instructed person or the use of ready-made leads or cords.

**WARNING:** To prevent fire or shock hazard, do not expose this equipment to rain or moisture.

**WARNING:** An apparatus with Class I construction shall be connected to a mains socket-outlet with a protective earthing connection.

## 2. IMPORTANT SAFETY INSTRUCTIONS

1. Read these instructions.
2. Keep these instructions.
3. Heed all warnings.
4. Follow all instructions.
5. Do not use this apparatus near water.
6. Clean only with dry cloth.
7. Do not block any ventilation openings. Install in accordance with the manufacturer’s instructions.

8. Do not install near any heat sources such as radiators, heat registers, stoves, or other apparatus (including amplifiers) that produce heat.
9. Do not defeat the safety purpose of the polarized or grounding type plug. A polarized plug has two blades with one wider than the other. A grounding type plug has two blades and a third grounding prong. The wide blade or the third prong are provided for your safety. If the provided plug does not fit into your outlet, consult an electrician for replacement of the obsolete outlet.
10. Protect the power cord from being walked on or pinched particularly at the plugs, convenience receptacles, and at the point where they exit from the apparatus.
11. Only use attachments/accessories specified by the manufacturer.
12. Unplug the apparatus during lightening sorts or when unused for long periods of time.
13. Refer all servicing to qualified personnel. Servicing is required when the apparatus has been damaged in any way, such as power supply cord or plug is damaged, liquid has been spilled or objects have fallen into the apparatus, the apparatus has been exposed to rain or moisture, does not operate normally, or has been dropped.
14. Disconnecting from mains: Switching off the POWER switch all the functions and light indicators of the amplifier will be stopped, but fully disconnecting the device from mains is done unplugging the power cord from the mains input socket. For this reason, it always shall remain readily operable.
15. Equipment is connected to a socket-outlet with earthing connection by means of a power cord.
16. The marking information is located at the bottom of apparatus.
17. The apparatus shall not be exposed to dripping or splashing and that no objects filled with liquids, such as vases, shall be placed on apparatus.

**NOTE:** *This equipment has been tested and found to comply with the limits for a Class A digital device, pursuant to part 15 of the FCC Rules. These limits are designed to provide reasonable protection against harmful interference when the equipment is operated in a commercial environment. This equipment generates, uses, and can radiate radio frequency energy and, if not installed and used in accordance with the instruction manual, may cause harmful interference to radio communications. Operation of this equipment in a residential area is likely to cause harmful interference in which case the user will be required to correct the interference at his own expense.*



**WARNING:** This product must not be discarded, under any circumstance, as unsorted urban waste. Take to the nearest electrical and electronic waste treatment centre.

**NEEC AUDIO BARCELONA, S.L.** accepts no liability for any damage that may be caused to people, animal or objects due to failure to comply with the warnings above.

### 3. IMPORTANT NOTE

Congratulations. You now own the result of a well-designed, carefully produced manufacture. We thank you for your trust by having chosen our eMOTUS50D outdoor loudspeaker.

To achieve its maximum working order and performance, it is VERY IMPORTANT, before connecting, to read this manual carefully. To guarantee optimum working order, we recommend that maintenance be carried out by our authorized Technical Services.

### 4. INTRODUCTION

eMOTUS50D is a 5" loudspeaker designed for installing outdoor. A compact, professional loudspeaker with great performance at a highly attractive price. Its fantastic performance and unique design mean that it can easily be integrated into a wide range of applications: theme parks, urban spaces, gardens, etc. Available in black and white.

### 5. KEY FEATURES

- 2-way cabinet, 5" woofer and 1" tweeter
- 40WRMS @ 8Ω
- Power selector: 3,75 / 7,5/ 15 / 30W @ 100V & 8Ω position
- Outdoor design
- IP65 rated
- Back rubber cover for connections
- Available in black and white colour

## 6. CONNECTING

eMOTUS50D accepts high or low impedance. In this regard, on the rear panel, there is a 5-position switch for selecting your work mode. The first 4 positions allow for the system to operate in high impedance, and the fifth, in low impedance. (\*) The 4 positions on the power selector for a 100V line will make it possible to set the maximum power with which each unit will operate. So, in areas where a low sound level is needed, the lower positions will be used (3.75 to 7.5W), whereas in areas where a higher level is required, the upper positions (15 or 30W) will be used.

**N.B.** In the event of using the loudspeaker in installations at 70V, the power ratings for the 100V position will be reduced to half of those indicated on the connector terminals. In the case of 50V installations, they will be reduced to a quarter.

The fifth position corresponds to operating in low impedance ( $8\Omega$ ) and a maximum power of 40 WRMS. In the event of adopting this set up, the limitations of the amplifier must be taken into account by connecting several loudspeakers to the output, particularly if the impedance of the unit falls below  $4\Omega$ . Also, it is important to ensure that the connection cable joining the amplifier outputs and the loudspeakers are good quality, and as short as possible. This becomes especially important when the distances to cover are considerable and the impedance of the loudspeakers is low.

(\*) **N.B.** The speaker distribution system on a 100V/70V line historically arises from the technical need to mix loudspeakers with different impedances and/or power ratings on the same line or amplifier channel, all without the need to be concerned about the total impedance of the resulting unit. In addition to that, this solution makes it possible, with minimum losses of power, to use long stretches of cable and a slightly shorter section than that normally used in a low impedance installation.

**CAUTION:** eMOTUS50D is delivered by default with the switch in the 100V/30W position. **If the system is accidentally connected to an amplifier with a low impedance output, no damage will be done to the loudspeaker, but it will perform well below its capacity. In the event of accidentally connecting the loudspeaker to a 100V network with the switch in the  $8\Omega$  position, it will be seriously damaged.**

## 7. POSITIONING, FITTING AND START-UP

In the packing of eMOTU50D, you will find all that is needed to complete installation of the unit.

The following should be observed as general rules:

- Always install on solid, firm surfaces.
- For good sound reproduction, there should be no hindrance between the units and the audience.
- Adjust the levels of sound pressure to reproduction requirements. Despite its small size, the eMOTUS50D has a performance far higher than that of domestic loudspeakers.

Procedure for installing **on a surface**:

1. Make three 6 mm drill holes in the wall, lining them up with the position of the holes in the bracket.
2. Insert three 6 mm wall plugs in these holes.
3. Fasten the safety line on the back of the bracket.

4. Place the bracket in position, after first passing the line and the loudspeaker cable through the square hole on the bracket. Fix the bracket to the wall. Connect the loudspeaker cable to the connector on the rear part of the box, using the Euroblock connector supplied. Ensure the correct polarity of the terminals and that the cable goes through the square hole in the bracket. It is advisable to place the protective housing supplied when the loudspeaker is installed outdoors.

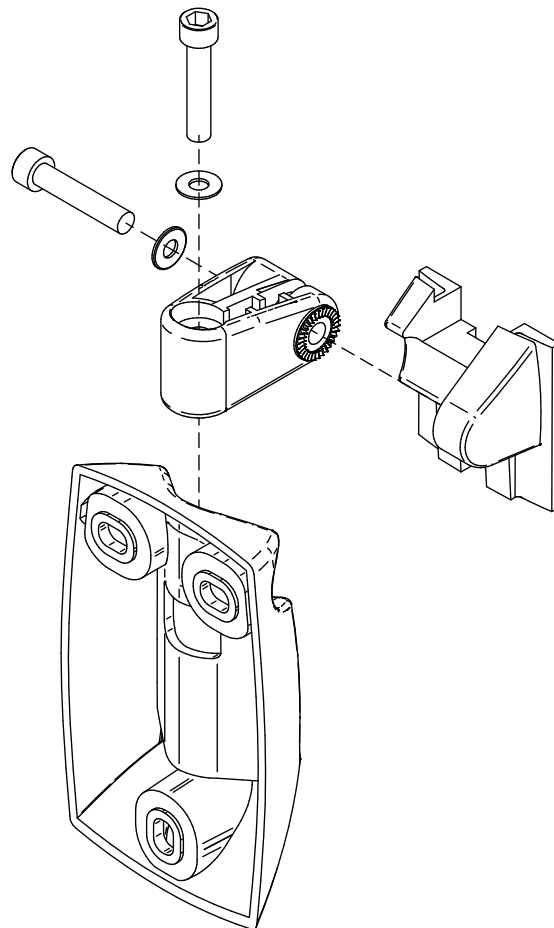

5. Place the acoustic box in its final position, vertically sliding it downward so that the rail on its rear side fits with the bracket rail. Fasten the safety cable on the rear part of the acoustic box, to avoid it accidentally falling and causing material and/or personal damage.
6. Orientate the box to obtain the required position on the vertical and horizontal axes. Tighten the Allen screws on the bracket to fix said position on both axes.
7. Adjust the power selector to the required position.



## 8. REAR PANEL

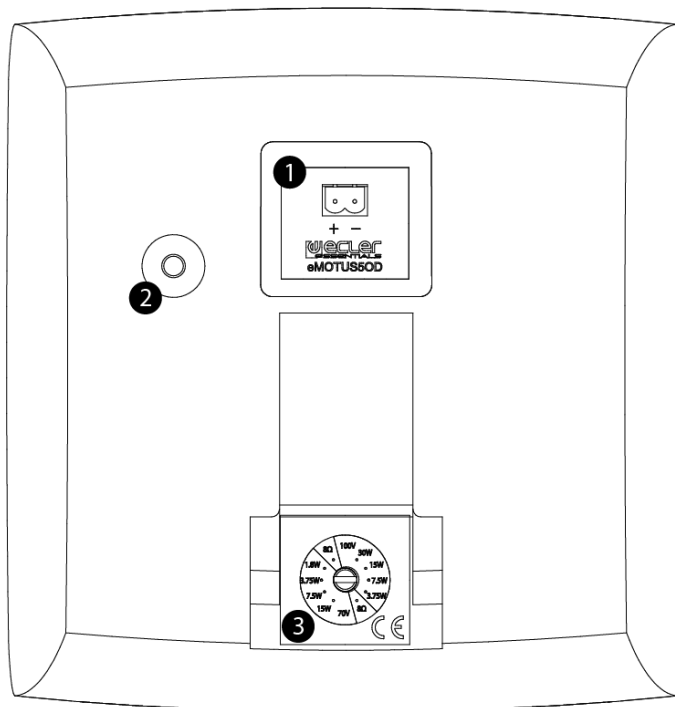

1. 2-terminal Euroblock connector
2. Attachment point for the safety cable
3. Power selector

## 9. TECHNICAL SPECIFICATIONS

eMOTUS50D	
<b>Power</b>	40 WRMS / 80 W Program
<b>Impedance</b>	8 Ω / 100V
<b>Power selector</b>	30W / 15W / 7.5W / 3.75W & 8Ω
<b>Frequency response (±10dB)</b>	85Hz – 20kHz
<b>Construction</b>	Aluminum grill, ABS cabinet
<b>Dimensions (WxDxH)</b>	173x181x180mm - Not including brackets; 173x248x180mm - Including brackets
<b>Weight</b>	4.8 kg – Not including accessories; 5.3 kg – Including accessories

## 10. PACKING CONTENT

- 2 x eMOTUS50D loudspeakers
- 2 x articulated brackets for wall mounting
- 5mm Allen key
- 2 x metal safety lines against any possible flaking off, with corresponding screws and lock washers.
- 8 x adhesive legs for positioning the loudspeakers on a desktop
- Rear connection housing for outdoor use
- Quick reference guide
- Warranty card

All product characteristics are subject to variation due to production tolerances. **NEEC AUDIO BARCELONA S.L.** reserves the right to make changes or improvements in the design or manufacturing that may affect these product specifications.

Motors, 166-168 08038 Barcelona - Spain - (+34) 932238403 [information@ecler.es](mailto:information@ecler.es) [www.ecler.com](http://www.ecler.com)